



Assembly Instructions for US Version Slip-on Muffler for 2021-Up Harley Davidson® Pan America Models (550-1081)

DISCLAIMER:

Many S&S parts are designed for high performance, closed course, racing applications and are intended for the very experienced rider only. The installation of S&S parts may void or adversely affect your factory warranty. In addition such installation and use may violate certain federal, state, and local laws, rules and ordinances as well as other laws when used on motor vehicles used on public highways. Always check federal, state, and local laws before modifying your motorcycle. It is the sole and exclusive responsibility of the user to determine the suitability of the product for his or her use, and the user shall assume all legal, personal injury risk and liability and all other obligations, duties, and risks associated therewith.

DISCLAIMER: *Qualified manufacturer declared U.S. 50-State legal emissions replacement part on all 2021-2023 Pan America models

SAFE INSTALLATION AND OPERATION RULES:

Before installing your new S&S part, it is your responsibility to read and follow the installation and maintenance procedures in these instructions and follow the basic rules below for your personal safety.

- Gasoline is extremely flammable and explosive under certain conditions and toxic when breathed. Do not smoke. Perform installation in a well ventilated area away from open flames or sparks.
- If motorcycle has been running, wait until engine and exhaust pipes have cooled down to avoid getting burned before performing any installation steps.
- Before performing any installation steps, disconnect battery to eliminate potential sparks and inadvertent engagement of starter while working on electrical components.
- Read instructions thoroughly and carefully so all procedures are completely understood before performing any installation steps. Contact S&S with any questions you may have if any steps are unclear or any abnormalities occur during installation or operation of motorcycle with an S&S part on it.
- Consult an appropriate service manual for your motorcycle for correct disassembly and reassembly procedures for any parts that need to be removed to facilitate installation.
- Use good judgment when performing installation and operating motorcycle. Good judgment begins with a clear head. Don't let alcohol, drugs or fatigue impair your judgment. Start installation when you are fresh.
- Be sure all federal, state and local laws are obeyed with the installation.
- For optimum performance and safety and to minimize potential damage to carb or other components, use all mounting hardware that is provided and follow all installation instructions.
- Motorcycle exhaust fumes are toxic and poisonous and must not be breathed. Run motorcycle in a well ventilated area where fumes can dissipate.

IMPORTANT NOTICE:

Statements in this instruction sheet preceded by the following words are of special significance.



WARNING

Means there is the possibility of injury to yourself or others.



CAUTION

Means there is the possibility of damage to the part or motorcycle.

NOTE

Other information of particular importance has been placed in italic type.

S&S recommends you take special notice of these items.

WARRANTY:

All S&S parts are guaranteed to the original purchaser to be free of manufacturing defects in materials and workmanship for a period of twelve (12) months from the date of purchase. Merchandise that fails to conform to these conditions will be repaired or replaced at S&S's option if the parts are returned to us by the purchaser within the 12 month warranty period or within 10 days thereafter.

In the event warranty service is required, the original purchaser must call or write S&S immediately with the problem. Some problems can be rectified by a telephone call and need no further course of action.

A part that is suspect of being defective must not be replaced by a Dealer without prior authorization from S&S. If it is deemed necessary for S&S to make an evaluation to determine whether the part was defective, a return authorization number must be obtained from S&S. The parts must be packaged properly so as to not cause further damage and be returned prepaid to S&S with a copy of the original invoice of purchase and a detailed letter outlining the nature of the problem, how the part was used and the circumstances at the time of failure. If after an evaluation has been made by S&S and the part was found to be defective, repair, replacement or refund will be granted.

ADDITIONAL WARRANTY PROVISIONS:

- (1) S&S shall have no obligation in the event an S&S part is modified by any other person or organization.
- (2) S&S shall have no obligation if an S&S part becomes defective in whole or in part as a result of improper installation, improper maintenance, improper use, abnormal operation, or any other misuse or mistreatment of the S&S part.
- (3) S&S shall not be liable for any consequential or incidental damages resulting from the failure of an S&S part, the breach of any warranties, the failure to deliver, delay in delivery, delivery in non-conforming condition, or for any other breach of contract or duty between S&S and a customer.

1. Remove the stock muffler from the motorcycle you are working on. Keep the bolt that holds the muffler to the subframe, you will reuse this.
2. Remove the muffler box that mounts under the motorcycle and to the header. Save the stock clamp that goes from the muffler box to the header, you will reuse this.
3. Locate the three inserts from the hardware pack, illustrated in Picture 1.

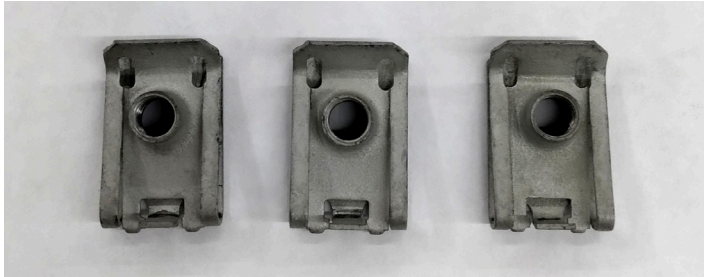

Picture 1

4. Slide one insert into the supplied clamp as illustrated in Picture 2.



Picture 2

5. Slide the supplied clamp with insert over the exhaust inlet tube and slightly snug. Install the other two inserts into the muffler body as illustrated in Picture 3.



Picture 3

6. Slide the OEM muffler clamp over the inlet tube of the S&S muffler and install the inlet tube over the stock header of the motorcycle as illustrated in Picture 4.

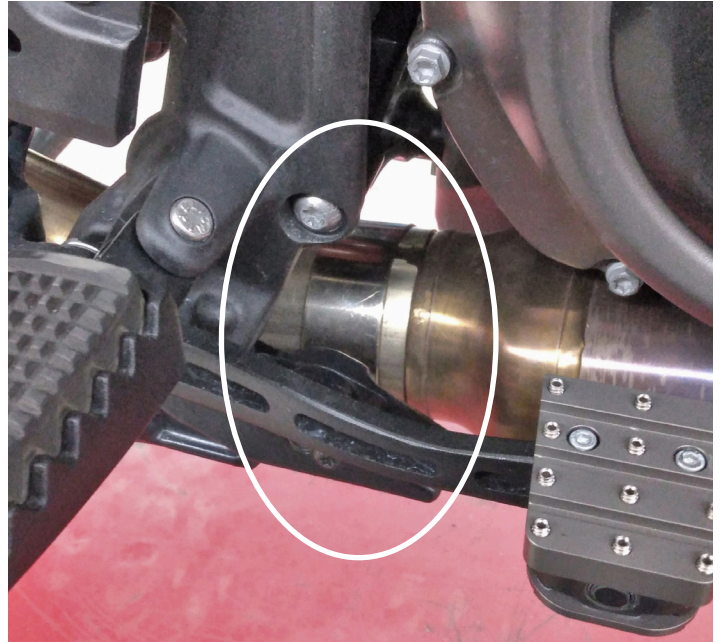

Picture 4

7. Using the bolt that was removed from the stock muffler to the subframe, install the bolt through the hanger Picture 5 and use the supplied nut and washer Picture 6 and hand tighten.

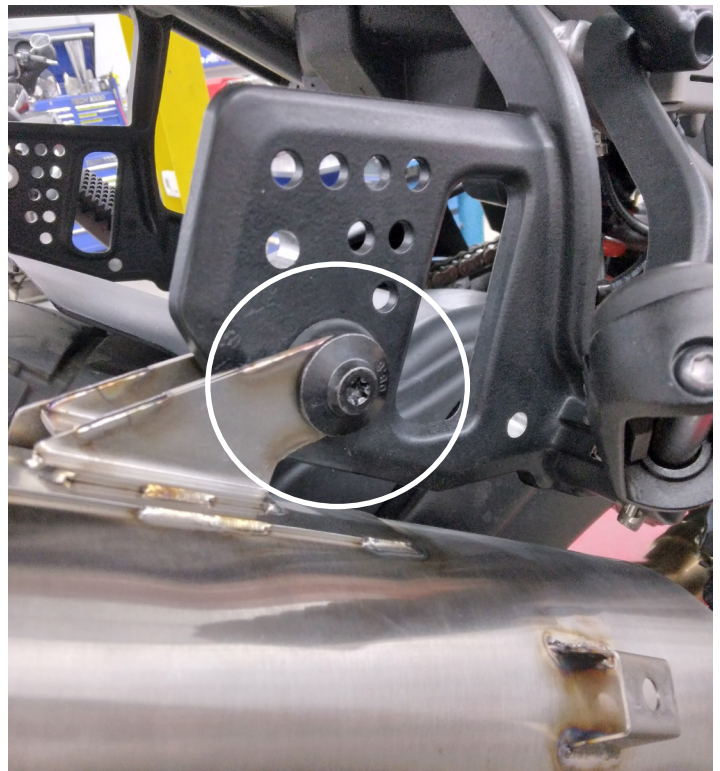

Picture 5

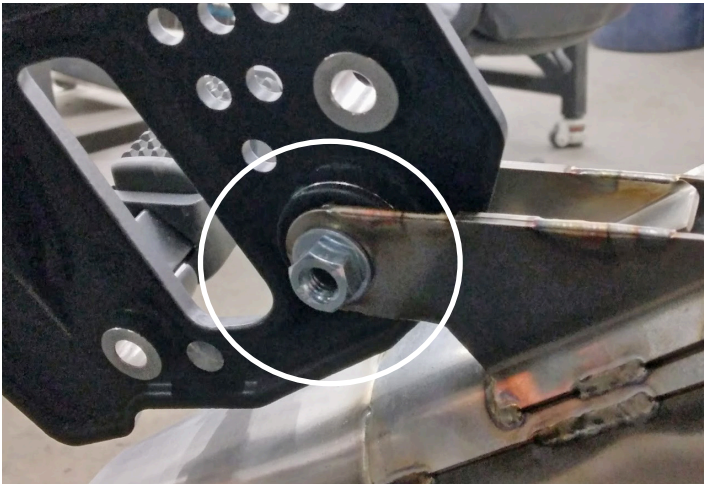

Picture 6

8. Locate the carbon fiber heat shield, stainless button head screws, stainless washers and wire mesh gaskets as illustrated in Picture 7.



Picture 7

9. Using the carbon fiber heat shield, hold it up to the muffler and muffler clamp to ensure the muffler clamp is rotated correctly, aligning all three holes as illustrated in Picture 8. Once alignment has been confirmed, finish tighten the clamp on the inlet tube.



Picture 8

10. Attach the carbon fiber heat shield to the muffler using the stainless washers and wire mesh gaskets. Wire mesh gaskets go on the inside of the heat shield and stainless washers go on the outside of the heat shield as illustrated in Picture 9 & 10.



Outside of Heat Shield

Picture 9



Inside of Heat Shield

Picture 10

11. Apply a drop of thread locker to the threads of the three stainless button head screws and attach the heat shield to the muffler. Screws should be snugged up and not over torqued.

12. Finish torque the nut and bolt that holds the muffler to the subframe, 15 lb./ft.

13. Finish torque the clamp that holds the muffler to the header, 15 lb./ft.

14. Wipe down exhaust to remove all grease, dirt and fingerprints prior to starting the bike.

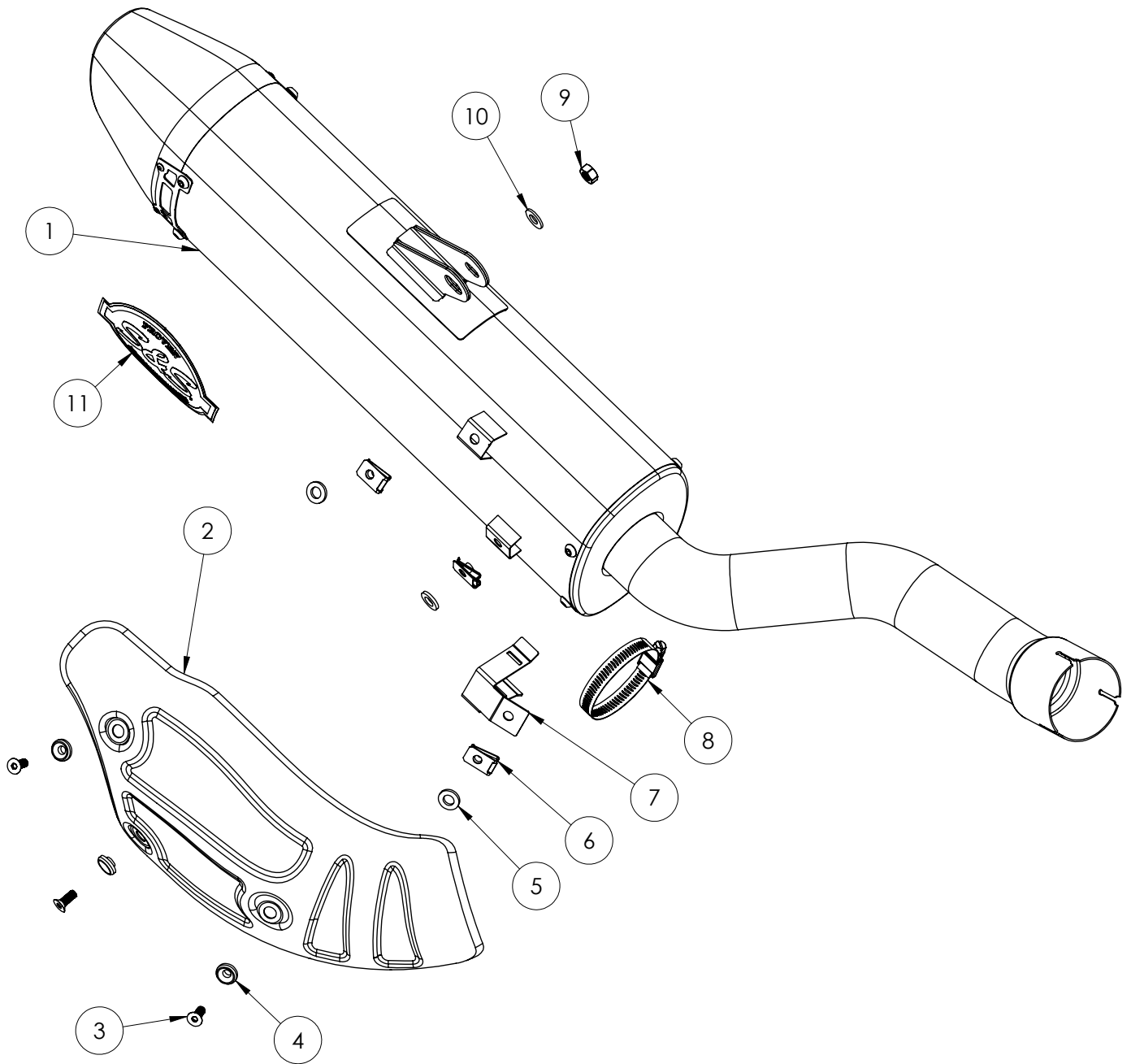

1. Muffer551-2014
2. Heatshield551-1980
3. FHSC Screw551-2151
4. Bushing551-2024
5. Mesh Washer551-2020
6. Clip-On Nut500-1134
7. Heat Shield Bracket551-2023
8. Hose Clamp551-0402
9. Lock Nut500-1860
10. Flat Washer50-7034
11. Decal510-1047